

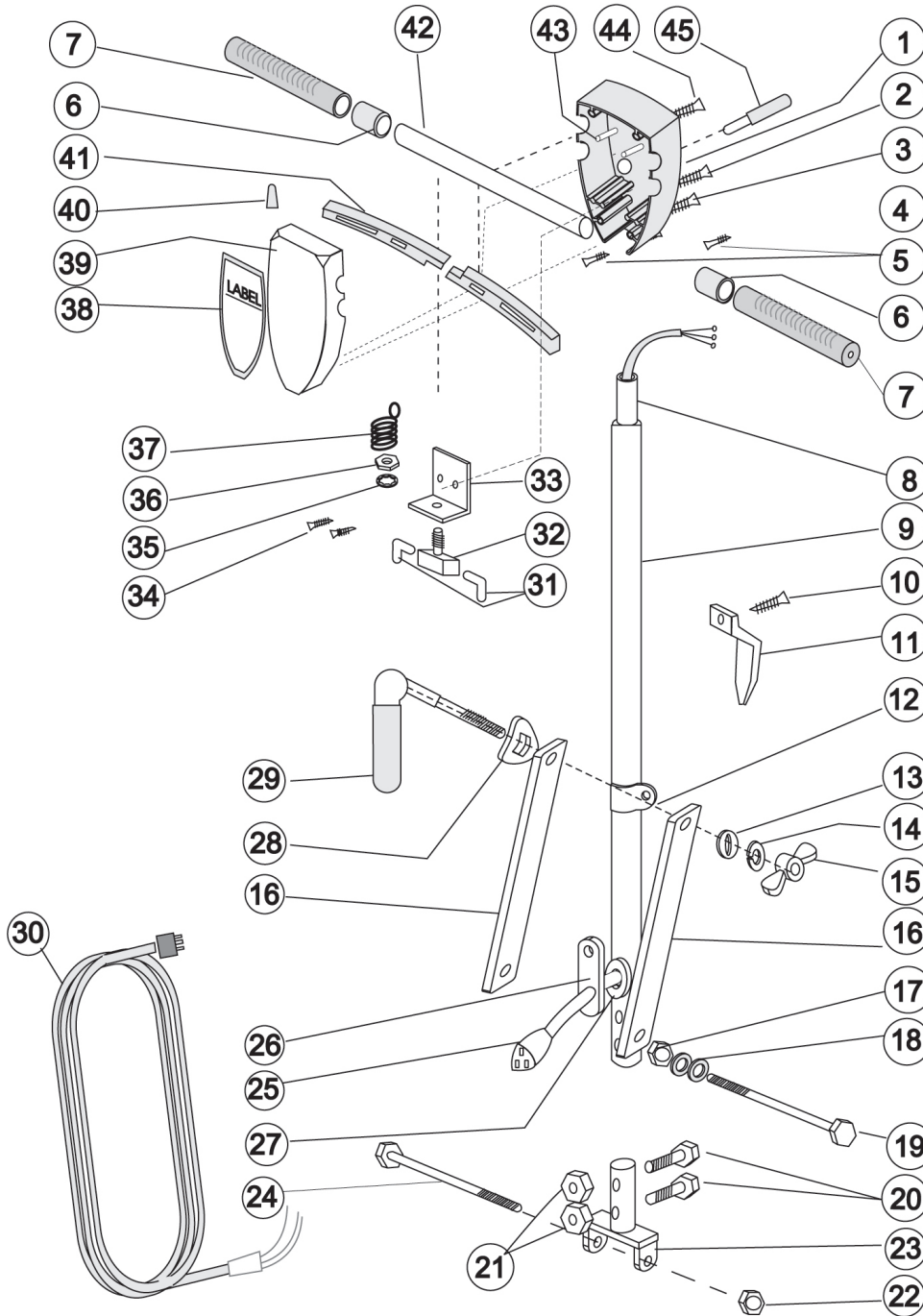

# Ultra D.C. High Speed Burnisher Handle Parts List





# Ultra D.C. High Speed Burnisher Handle Parts List

ITEM	DESCRIPTION	PART #	#
1	Switch Box Back Cover	A-104	1
2	Handle Tube Screw	B-23	2
3	Switch Box Closing Screws	B-21	4
4	Strain Relife Clip	M-213	1
5	Switch Plate Screw	B-68	2
6	Rubber Spacer - Yellow	M-218Y	2
7	Hand Grip	M-218	2
8	Handle Tube Insert	M-247	1
9	Handle Tube Assembly	M-206	1
10	Cable Hook Screw	B-2	2
11	Cable Hook	A-164	1
12	Sliding Collar	A-111	1
13	Flat Washer	B-37	1
14	Split Washer	B-39	1
15	Cam Lock Wing Nut	B-25	1
16	Straight Brace	M-233	2
17	Stop Nut	B-10	1
18	Washer	B-28	2
19	Cap Screw	B-9	2
20	Yoke Tube Mount Bolt	B-18A	2
21	Tube Mounting Nut	B-19	2
22	Yoke	A-1001	1
23	Yoke Nut	B10	1
24	Yoke Bolt	B14	1
25	Handle Tube Cable	G-16	1
26	Black Rubber Cable Connector	M-249	1
27	Cable Grommet	B-63	1
28	Rectangular Hole Cam Washer	B-67	1
29	Cam Assembly	C-100	1
29A	Complete Cam Assembly Kit (Includes 1 each Of Drawing Items #13, 14, 15, 28, 29)	CCA	1
30	50 Foot Cable 14/3	G-14-50	1
31	Insulated Flag Wire Connector	G-48	5
32	On-off Switch And Plate Assembly	G-30-AB	1
33	Switch Mounting Plate	G-30-B	1
34	Ground Wire Screw	B-1	2
35	Int. Tooth Lockwasher	B-35	1
36	Flat Hex Nut	B-33	1
37	Trigger Return Spring	G-30-C-T057	1
38	Label - Switchbox	Call For #	1
39	Switch Box Front	A-103	1
40	Wire Nut	G-47	1
41	Triggers	A-105	2
42	16" Crossbar	M-211-A	1
43	Trigger Pins	B-70	2
44	Cross Bar Screw	B-22	2
45	Safety Interlock Assembly	SIA-1	1



# Ultra D.C. High Speed Burnisher Machine Parts List

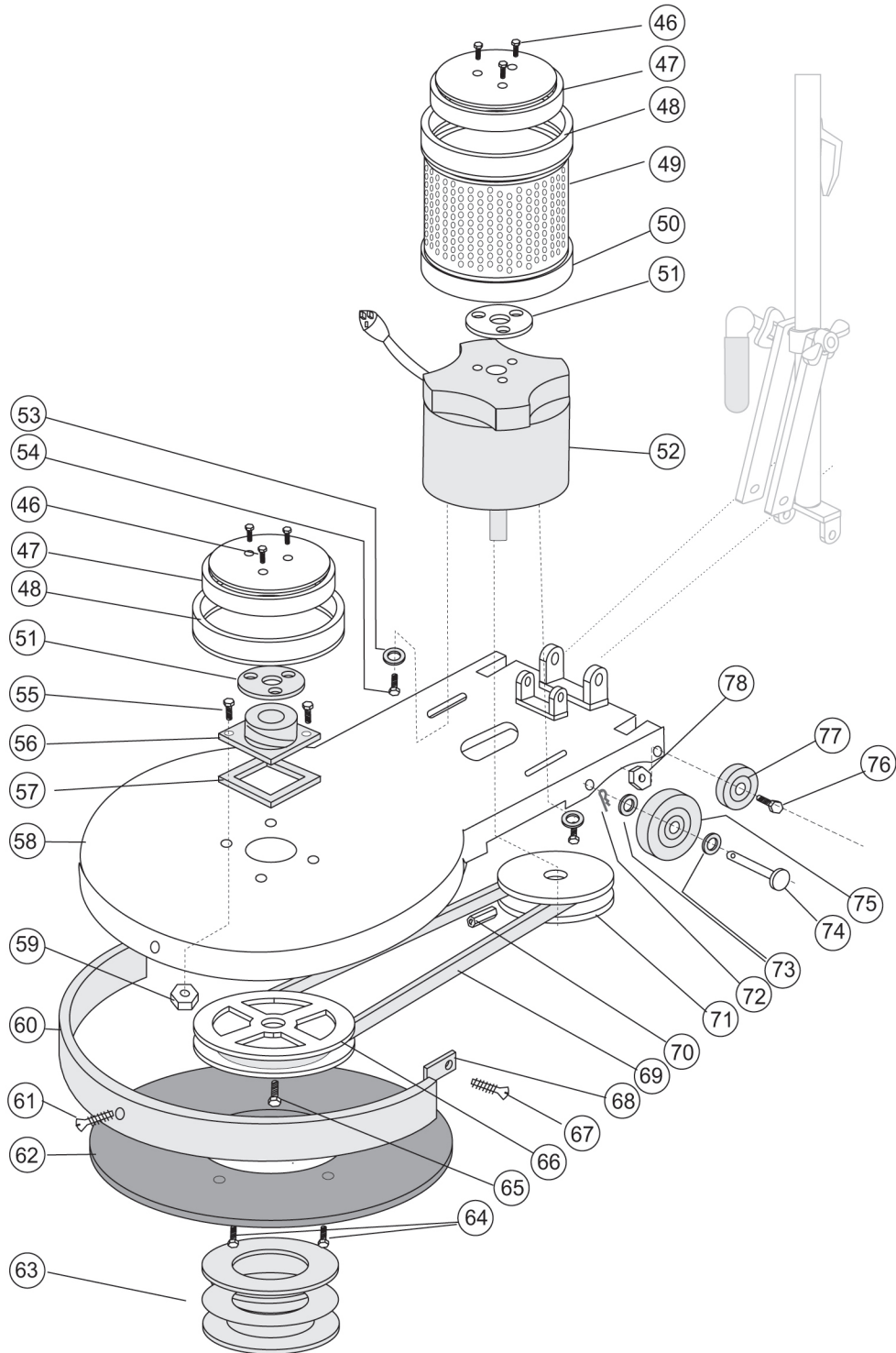



# Ultra D.C. High Speed Burnisher Machine Parts List

Drawing No.	Description	Part No.	Qty.
46	Drip Cap Mount Screw	B-151	6
47	66 Fr. Drip Cap Cover	M-242	2
48	66 Fr. Drip Cap Cover Bumper - Yellow	M-239-Y	2
49	UHS Motor Screen	SCR-01	1
50	UHS Motor Screen Bumper - Yellow	M-238-Y	1
51	Cork Drip Cap Gasket	M-248	2
52	UHS 1.5 HP Motor Only	MOTOR-DC-IMP	1
53	Washer	B-28	2
54	Motor Mount Bolt for UHS Motor	B-143	2
55	Bearing Block Assembly Mount Bolt	B-144	4
56	Bearing Block Assembly	BBA-1	1
57	Bearing Block Gasket	B-145	1
58A	Base Casting 19"	A-131	1
58B	Base Casting 20"	A-132	1
58C	Base Casting 21"	A-132	1
59	Motor Mount Lock Nut	B-150	4
60A	Bumper Stock for 19"	BUMPER STOCK	50"
60B	Bumper Stock for 20" or 21"	BUMPER STOCK	56"
61	Ground Wire Screw	B-68	3
62A	Floppy Disk Driver 19"	DC-18	1
62B	Floppy Disk Driver 20"	DC-20	1
62C	Floppy Disk Driver 21"	DC-20	1
63	Big Mouth Blue Retainer	PR7-ABL	1
64	Screw	B-95	4
65	Allen Head Screw	B-149	1
66	Pulley Driver	PD-1	1
67	Bumper Screw	B-68	1
68A	Bumper Strap for 19"	BUMPER STRAP	56"
68B	Bumper Strap for 20" or 21"	BUMPER STRAP	62"
69A	Drive Belt DC-1500 and 1170	DB-2	1
69B	Drive Belt DC-2000	DB-1	1
70	Allen Head Set Screw For PD	B-149	1
71A	Pulley To Fit Motor 1500 RPM DC	PM-3	1
71B	Pulley To Fit Motor 1170 RPM DC	PM-2	1
71C	Pulley To Fit Motor 2000 RPM DC	PM-1	1
72	Cotter Pin Wheel Axel	B-142	2
73	Spring Washer	B-51	4
74	Wheel Axel	B-16	2
75	6" Operating Wheel	M-250	2
76	Transport Wheel Axel Bolt	B-26	2
77	4" Transport Wheel	M-209	2
78	Lock Nut	B-77	2
79	Front Wheel Assembly	FCA-1	1